

DIN 985

Dado esagonale basso autofrenante con inserto non metallico

Prevailing torque type hexagon thin nut, with non-metallic insert

Disponibile/Available

A2  A4 

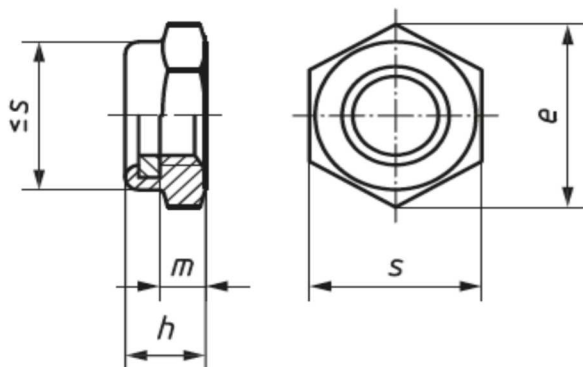

	M3	M4	M5	M6	M7	M8	M10	M12	M14	M16	M18		
Thread	—	—	—	—	—	M 8 x 1	M 10 x 1	M 12 x 1,5	M 14 x 1,5	M 16 x 1,5	M 18 x 2		
	—	—	—	—	—	—	M 10 x 1,25	M 12 x 1,25	—	—	M 18 x 1,5		
$P^{1)}$	0,5	0,7	0,8	1	1	1,25	1,5	1,75	2	2	2,5		
e min.	6,01	7,66	8,79	11,05	12,12	14,38	18,9	21,1	24,49	26,75	29,56		
h	max. = nom.		4	5	5	6	7,5	8	10	12	14	16	18,5
	min.		3,7	4,7	4,7	5,7	7,14	7,64	9,64	11,57	13,3	15,3	17,66
m min.	2,4	2,9	3,2	4	4,7	5,5	6,5	8	9,5	10,5	13		
s	max. = nom.		5,5	7	8	10	11	13	17	19	22	24	27
	min.		5,32	6,78	7,78	9,78	10,73	12,73	16,73	18,67	21,67	23,67	26,16

	M20	M22	M24	M27	M30	M33	M36	M39	M42	M45	M48		
Thread	M 20 x 2	M 22 x 2	M 24 x 2	M 27 x 2	M 30 x 2	M 33 x 2	M 36 x 3	M 39 x 3	M 42 x 3	M 45 x 3	M 48 x 3		
	M 20 x 1,5	M 22 x 1,5	—	—	—	—	—	—	—	—	—		
$P^{1)}$	2,5	2,5	3	3	3,5	3,5	4	4	4,5	4,5	5		
e min.	32,95	35,03	39,55	45,2	50,85	55,37	60,79	66,44	72,09	76,95	82,6		
h	max. = nom.		20	22	24	27	30	33	36	39	42	45	48
	min.		18,7	20,7	22,7	25,7	28,7	31,4	34,4	37,4	40,4	43,4	46,4
m min.	14	15	15	17	19	22	25	27	29	32	36		
s	max. = nom.		30	32	36	41	46	50	55	60	65	70	75
	min.		29,16	31	35	40	45	49	53,8	58,8	63,8	68,1	73,1

$P^{1)}$ è il passo del filetto

$P^{1)}$ is the pitch of the thread.

I diametri M2,5 e M2 non sono previsti dalla norma DIN 985 e possono essere considerati similar

M2,5 and M2 thread sizes aren't DIN 985 standard but you can consider them similar DIN

last edit 10/07/2019

DRAWING N. 1088